



Air hydraulic jack engineered and manufactured to offer a solution that is safe and easy to use.

Main features:

- light, compact, easy to handle
- folding handle
- standard remote control
- pneumatic tyres for any surface

Sollevatore oleopneumatico progettato e costruito per offrire una soluzione sicura e di facile utilizzo.

Caratteristiche principali:

- estrema leggerezza, compattezza e maneggevolezza
- manico pieghevole
- comando remoto di serie
- ruote pneumatiche per qualsiasi superficie



M150-90

**SUITABLE FOR
ADATTO A**

Mine and oil field / Construction site
Industrial assembly / Agriculture / Railway applications / Military
*Miniera e giacimento petrolifero / Cantiere
Assemblaggio industriale / Agricoltura / Applicazioni ferroviarie / Militare*



	Capacity Portata	Net weight Penso netto	Working air press. Press. di alimentazione	Air consumption Consumo d'aria	Max. height Altezza max.	Min. height Altezza min.	Number of pistons Numero sfili	Stroke Corsa
M150-90	150 t 165,3 ton	377 Kg 831 lb	10-12 bar 145-174 psi	600 nl/min	1455 mm 57.2 in	901 mm 35.4 in	1	554 mm 21.8 in



Dimensions - Dimensionali

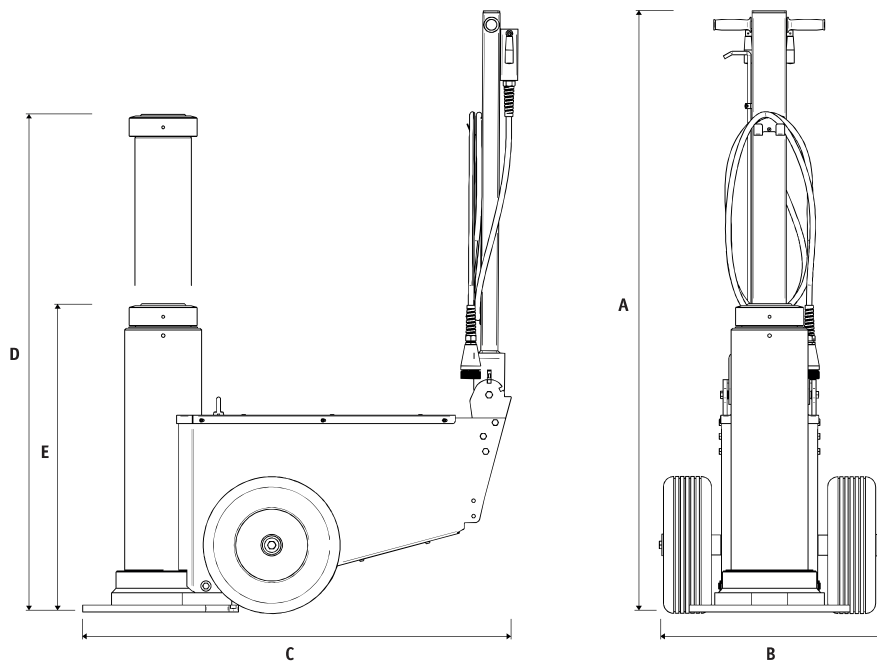

A	1757 mm 69,2 in
B	620 mm 24,4 in
C	1253 mm 49,3 in
D	1455 mm 57,3 in
E	901 mm 35,5 in

Accessories - Accessori



A00789



A06051



A06052



A02421



A02422



A02423



A04495

Code Codice	Description Descrizione
A00789	Safety Blocks Kit Kit Blocchi di Sicurezza
A06051	Extension Holder R Portaprolunghe DX
A06052	Extension Holder L Portaprolunghe SX
A02421	Extension Prolunga A: 200mm B: 55mm C: 55mm
A02422	Extension Prolunga A: 250mm B: 55mm C: 55mm
A02423	Extension Prolunga A: 300mm B: 55mm C: 55mm
A04495	Tilting plate Piatello basculante A: 77mm B: 55mm

A00789 KIT:

- 1x Safety Lock Holder - *Portablocchi*
- 5x Safety Block - *Blocco di sicurezza* - H100 - 216 mm
- 1x Safety Block - *Blocco di sicurezza* - H50 - 216 mm

