



**PORTABLE DISPLAY**



**PARTICULARLY SUITABLE FOR MOBILE SERVICE  
AND FOR THOSE WHO HAVE LITTLE ROOM IN THE WORKSHOP**



**Portable wheel balancer for truck and bus wheels  
Can be mounted on any type of spindle-operated truck tyre changer**



# MT6310 TRUCK

- ✓ **Compact and light wheel balancer** for truck and bus wheels
- ✓ **Small size and weight** facilitate movement and use
- ✓ **Easy and quick mounting system** on any type of truck tyre changer.
- ✓ Suitable for **mobile service** and for those who have little room in the workshop
- ✓ **Low rotation speed**
- ✓ **Manual wheel size launch and entry**
- ✓ **Weather-resistant** thanks to IP41 protection
- ✓ Complete with **all balancing programs:**  
**Dynamic - Static and ALU** for alloy rims.



**Portable, magnetically fixed display, powered with rechargeable batteries** and easy to use



Complete with **support for housing the measuring unit, display and centring kit**

## Technical data

Power supply	12Vdc 115÷230 Vac 50/60Hz 0,018kW
Protection rating	IP41
Shaft diameter	40mm
Cycle time for wheel	8 ÷ 20 s
Balancing speed	< 70 rpm
Measurement uncertainty	10g
Average noise	< 70dB(a)
Settable rim width	1,5" ÷ 20" (40 ÷ 510 mm)
Settable diameter	10" ÷ 30" (265 ÷ 765 mm)
Maximum wheel weight	< 250 kg
Machine weight	~ 20 kg

## Overall dimensions

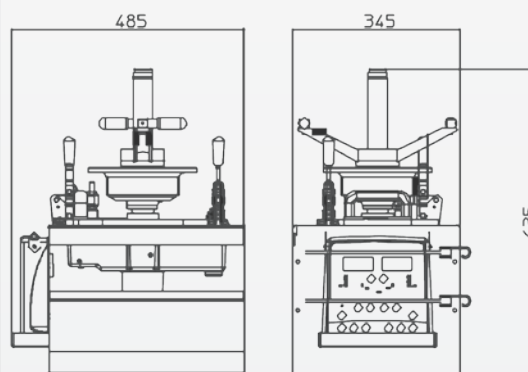

## Equipment



## Recommended accessories



**ART 40** - truck flange centring kit