

One Lift for Double Solutions

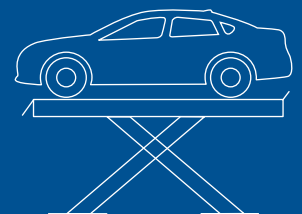

Very versatile:

the same lift can be flush or floor mounted

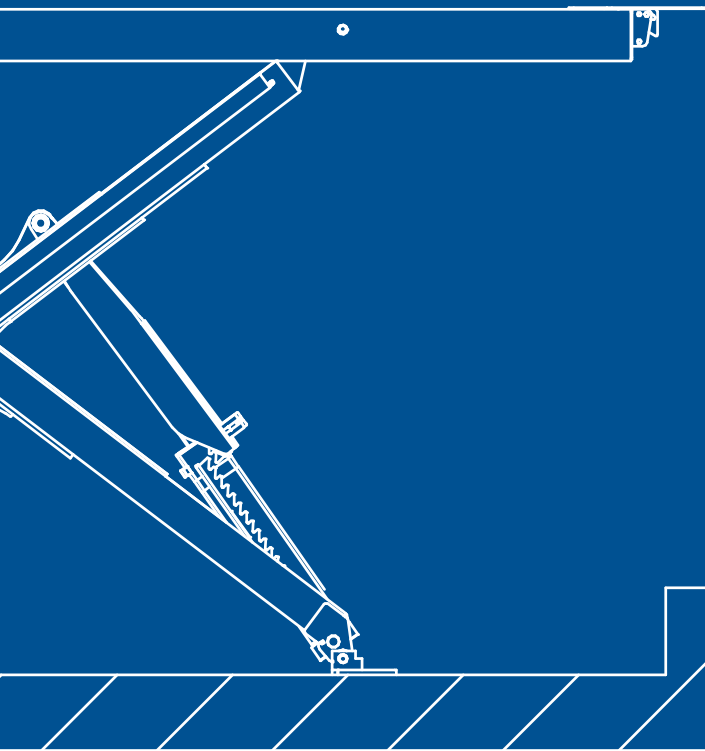

Easy installation:

easy setting up of pit

Wide ranging applications:

suitable for different operations on various types of vehicle



The new lift geometry simplifies the flush mounting pit construction. **Lifts with big platforms,** structured and designed for maximum stability also when loaded with large vehicles.

Ramps kit.

All lifts are supplied for recessed installation. The drive on ramp kit enables to convert the lift from flush mounted to floor version.

NEW



GROUND RAMPS - 1350 mm

S600NA11

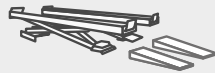

S600NA12



GROUND RAMPS - 1800 mm

S600NA14



S600NA13



RSUSPENDED RAMPS - 1560 mm

S600NA19



S600NA18



SUSPENDED RAMPS - 2000 mm

S600NA21



S600NA20



Open flush mounting for turntables.

Edge-free platforms that allow the turntables to be positioned over the entire surface of the platform width. Ideal when working on vehicles with narrow track.

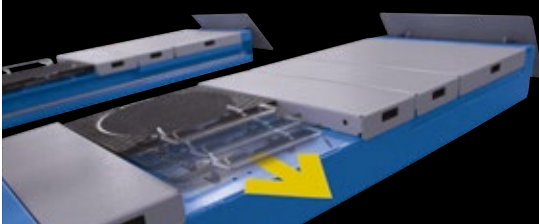

Optimal sliding of jacking beam.

Pre-installed galvanised guide on the inner side of the platform, which allows fast and smooth sliding of the jacking beam.





Large wheel stop for high working safety.



Integrated wheel free lift with levelling system to ensure a completely flat working surface.

Pre-drilled platform for Ravaglioli 3D wheel alignment measuring heads brackets housing. (For .2 and .5 models only).



Greater lifting height.



PATENTED

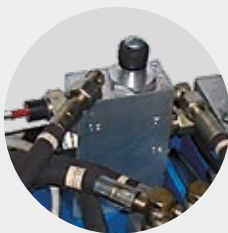

The hydraulic synchronisation of the platform movements is independent of the load distribution, and is guaranteed by a **patented hydraulic synchronisation device**.



All pivoting points are equipped with maintenance free **self lubricating bushings**.



Base plates with levelling system for an easy installation.



Mechanical locking device with automatic engagement and pneumatic release, ensuring **maximum safety** when lift is in parking position.

The new lift geometry simplifies the flush mounting pit construction.

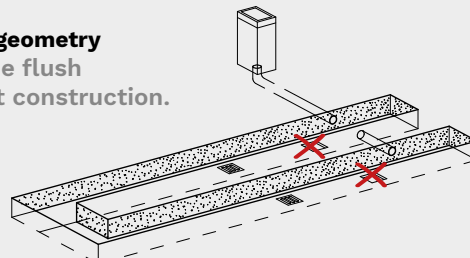

Lifts with flat platforms.

Lifts with big platforms, up to 5.5 m. length, structured and designed for maximum stability also when loaded with large vehicles.



Wheel alignment lifts.

Platforms for total wheel alignment with front housing for turn tables and rear side slip plates.



3

Alignment lifts with built in play detector.

Platforms for total alignment with front seats for turntables, rear rocking surfaces and play detector.

.5

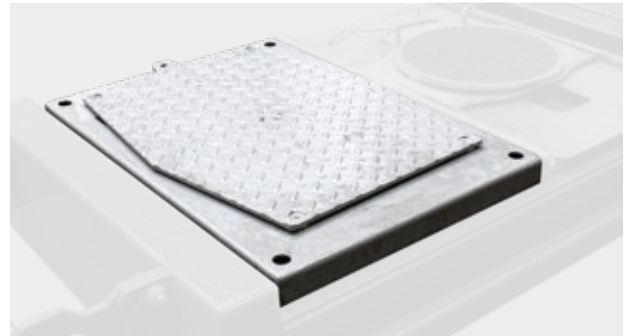

Plate with embossed surface to prevent plate-wheel sliding.

RAV 640N.3 - RAV 640N.4
4 movement play detector.

RAV650N.5 - RAV650N.6
8+4 movement play detector (8 movement play detector, 2014/45EU compliant).

Play detector torch

- Led technology
- Light weight
- Ergonomic control

4

Lifts with built in play detector.

.6

Technical Data

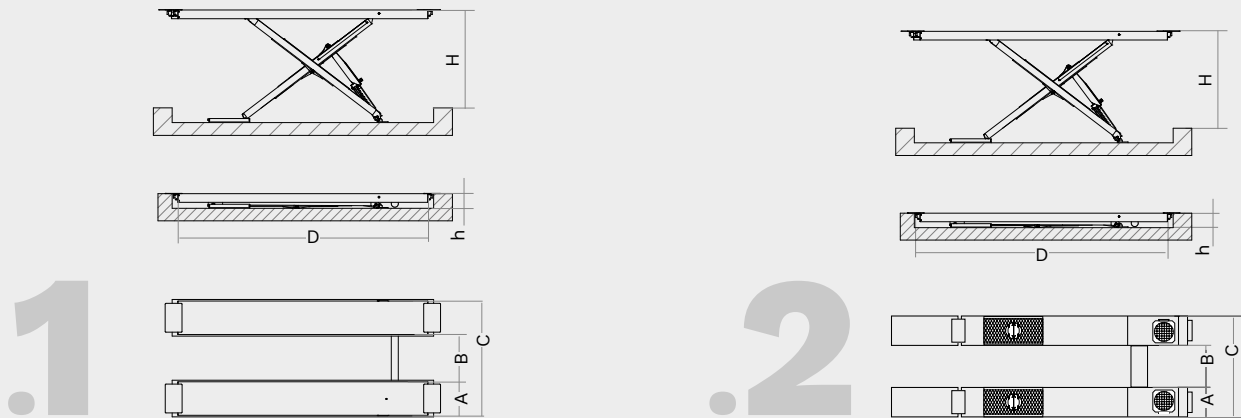

	Item no.	Capacity	Motor	A	B	C	D	h	H	TEq-Link
.1		kg	kW	mm	mm	mm	mm	mm	mm	
RAV640N.1I	RAV.640N1.193278	4200	2.6	615	870	2100	4600	270	1800	
RAV640N.1ISI	RAV.640N1.193391	4200	3.5	615	870	2100	4600	295	1805	
RAV650N.1.55I	RAV650N1.193728	5000	2.6	650	900	2200	5500	270	1805	
RAV650N.1.55ISI	RAV650N1.193742	5000	3.5	650	900	2200	5500	295	1805	
RAV660N.1.55I	RAV.660N1.193186	6000	2.6	650	900	2200	5500	270	1805	
.2		kg	kW	mm	mm	mm	mm	mm	mm	
RAV640N.2I	RAV.640N2.193117	4200	2.6	615	870	2100	4600	270	1800	
RAV640N.2ISI	RAV.640N2.193469	4200	3.5	615	870	2100	4600	295	1805	
RAV640N.2ISI (400-230/3/60Hz)	RAV.640N2.193001	4200	3.5	615	870	2100	4600	295	1805	
RAV640N.2ISIQ	RAV.640N2.193582	4200	3.5	615	870	2100	4600	295	1805	✓
RAV640N.2.42ISI	RAV.640N2.193216	4200	3.5	615	870	2100	4200	295	1805	
RAV650N.2.55I	RAV.650N2.193797	5000	2.6	650	900	2200	5500	270	1805	
RAV650N.2.55ISI	RAV.650N2.193858	5000	3.5	650	900	2200	5500	295	1805	
RAV650N.2.55ISI (400-230/3/60Hz)	RAV.650N2.193520	5000	3.5	650	900	2200	5500	295	1805	
RAV650N.2.55ISIQ	RAV.650N2.193667	5000	3.5	650	900	2200	5500	295	1805	✓
RAV660N.2.55I	RAV.660N2.193322	6000	2.6	650	900	2200	5500	270	1805	
RAV660N.2.55ISI	RAV.660N2.193360	6000	3.5	650	900	2200	5500	295	1805	

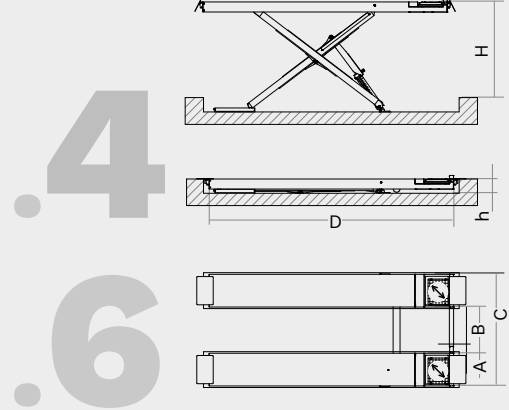
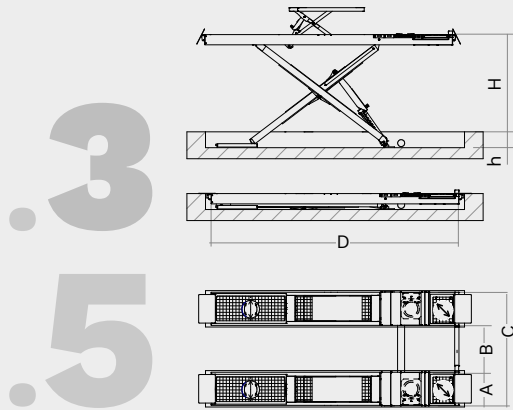

	Item no.	Capacity	Motor	A	B	C	D	h	H	MIT APPROVED
.3 .5		kg	kW	mm	mm	mm	mm	mm	mm	
RAV640N.3.46ISI	RAV.640N3.192981	4200	2.6	615	870	2100	4600	295	1805	
RAV640N.5.55ISI	RAV.640N5.193049	4200	2.6	650	900	2200	5500	295	1805	
RAV650N.5.55ISI	RAV.650N5.193902	5000	2.6	650	900	2200	5500	295	1805	
RAV650N.5.55ISI	RAV.650N5.193018	5000	2.6	650	900	2200	5500	295	1805	
.4 .6		kg	kW	mm	mm	mm	mm	mm	mm	
RAV640N.4.46I	RAV.640N4.193063	4200	2.6	615	870	2100	4600	270	1800	
RAV640N.4.46ISI	RAV.640N4.192998	4200	2.6	615	870	2100	4600	295	1805	
RAV640N.6.55I	RAV.640N6.193032	4200	2.6	650	900	2200	5500	270	1805	
RAV640N.6.55ISI	RAV.640N6.193056	4200	2.6	650	900	2200	5500	295	1805	
RAV650N.6.55ISI	RAV.650N6.193964	5000	2.6	650	900	2200	5500	295	1805	
RAV650N.6.55ISI	RAV.650N6.193025	5000	2.6	650	900	2200	5500	295	1805	

ISI MODELS

Versions with wheel free lift

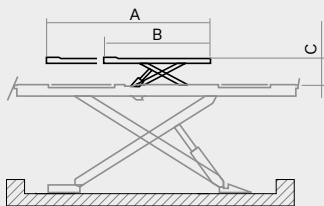

	Capacity	A	B	C
	kg	mm	mm	mm
SERIES RAV640N.ISI	3500	2000	1390	500
SERIES RAV640N.55ISI	4000	2100	1390	490
SERIES RAV650N.55ISI	4000	2100	1390	490
SERIES RAV660N.55ISI	4000	2100	1390	490

MODELLI MIT APPROVED

Approved versions for Italian audits

Distance between platforms	Cycle time
800 mm	< 1 min

Accessories

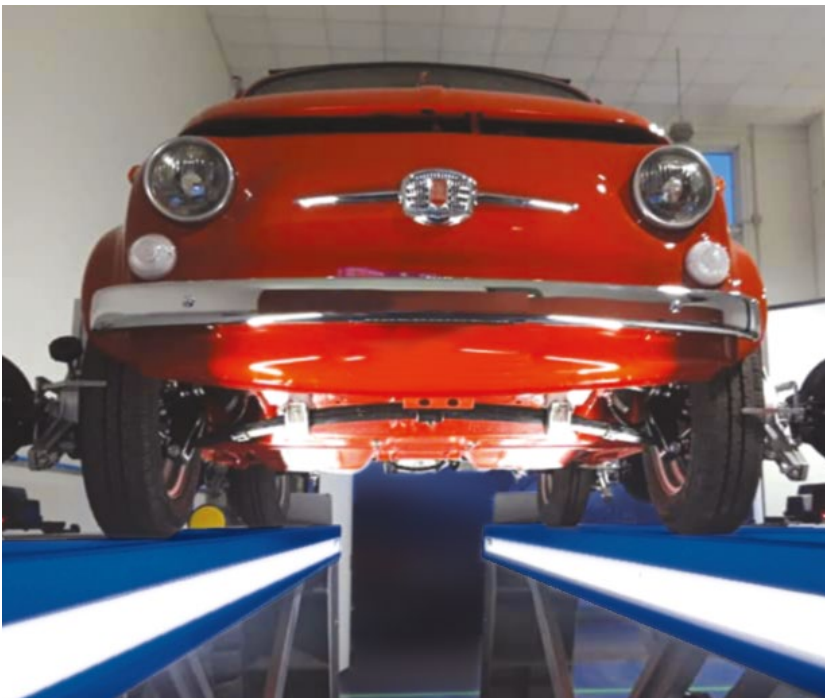

VAR600NA1
Lighting kit.

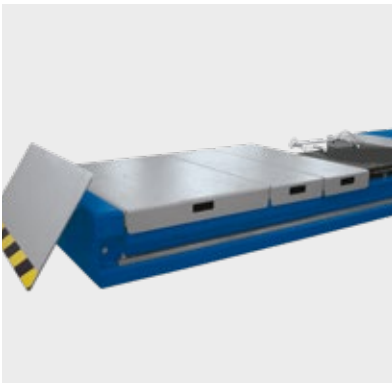

S650NA5 - S640NA5
Set of spacers to completely close turntable housing. (As a replacement for turntables). The remaining spacers are included.



S110A7 (2 x kit)
Turntables for wheel alignment.



VAR600NA1

4 LED bars, 24 V

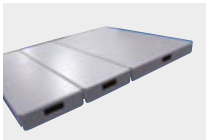

S650NA5 - S640NA5

Set of spacers to completely close turntable housing



S110A7 (2 x kit)

Turntables for wheel alignment



S505A2 (2 x kit)



S505A1

Set of pads H=200 mm



S505A5 - S505A9 - S505A6 - S505A7

H=120 mm - H=60 mm - H=40 mm - H=20 mm
Set of pads



RAV Italy

Vehicle Service Group Italy S.r.l.

Via Filippo Brunelleschi 9
44020 Ostellato (FE)
Italy

☎ +39.051.6781511
☎ +39.051.846349
✉ rav@ravaglioli.com

RAV France

RAV France SARL

4, Rue De Longue Raie
ZAC de la Tremblaie
91220 Le Plessis Pâté
France

☎ +33.1.60.86.88.16
☎ +33.1.60.86.82.04
✉ rav@ravfrance.fr

RAV Germany

BlitzRotary GmbH

Hüfingener Straße 55
78199 Bräunlingen
Germany

☎ +49.771.9233.0
☎ +49.771.9233.99
✉ ravid@ravaglioli.com

RAV UK

Vehicle Service Group UK Ltd

3 Fourth Avenue,
Bluebridge Industrial Estate
Halstead, Essex, CO9 2SY
United Kingdom

☎ +44.1787.477711
☎ +44.1787.477720
✉ rav@ravaglioli.com

DRD44U(01)

Technical data and composition presented in this catalogue may vary.
Pictures reproduced are only indicative.

Member of VSG - Vehicle Service Group
a  company

