



COMPANY WITH
QUALITY SYSTEM
CERTIFIED BY DNV GL
= ISO 9001 =

Double Carriage Movement



- SMONTAGOMME
- TYRE CHANGERS
- MONTIERMASCHINEN
- DEMONTÉ-PNEUS
- DESMONTADORAS

G
10360.15
9256.15
9256.11
SERIES

Smontagomme elettroidraulico per pneumatici di autocarri, macchine agricole e movimento terra. Il mandrino garantisce la presa senza prolunghe fino a cerchi di 43" (e 56"/60" con prolunghe).

Electrohydraulic tyre changer for trucks, agricultural and earthmoving vehicles. The chucking table can accommodate rims up to 43" without extensions (and 56"/60" with extensions).

Elektrohydraulische Reifenmontiermaschinen für Reifen von LKWs sowie Landwirtschafts- und Erdbewegungsmaschinen. Aufspannung bis 43" (und 56"/60" mit Verlängerungen).

Démonté-pneus électrohydrauliques pour pneus de poids lourds, machines agricoles et engins de terrassement. Prise des jantes jusqu'à 43" (et 56"/60" avec rallonges).

Desmontadora electrohidráulica para neumáticos de camiones, máquinas agrícolas y movimientos de tierra. Agarre hasta de 43" (y 56"/60" con prolongaciones).

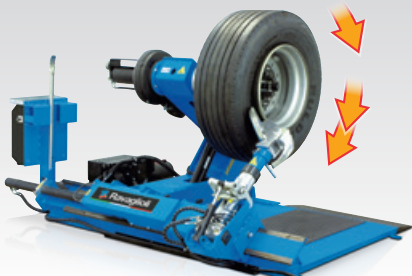

DOUBLE ROTATION SPEED

Doppia velocità su movimento rotazione mandrino
Double speed for chucking table rotation
Spannvorrichtung mit doppelter Drehgeschwindigkeit
Double vitesse pour rotation du mandrin
Doble velocidad en movimiento rotación del plato

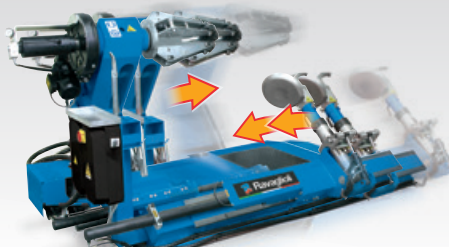

DOUBLE SPEED MOVEMENTS

Doppia velocità su movimenti idraulici
Double speed on hydraulic movement
Doppelte Geschwindigkeit bei hydraulischen Bewegungen
Double vitesse pour rotation du mandrin
Doble velocidad en los movimientos hidráulicos

STAND-BY FUNCTION

5"

Dopo 5 secondi di inutilizzo il motore si spegne.
After 5 sec. without being used, the motor turns off.
Bei nicht Benutzung geht nach 5 Sek. das Aggregat in Standby.
Après 5 secondes sans utilisation le moteur s'éteint.
Después de 5 segundos de no utilizzo el motor se apaga.





G 10360.15

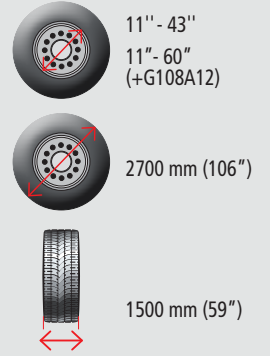

G 9256.15

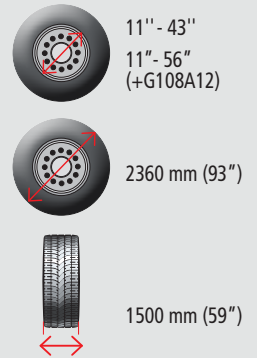

AUTOMATIC LIFTING



AUTOMATIC MOVEMENT



AUTOMATIC ROTATION



CONTROL UNIT



- 1 CLAMPS MOVEMENT
- 2 BEAD BREAKING ARM MOVEMENT
- 3 DOUBLE SPEED
- 4 BEAD BREAKING ARM ROTATION
- 5 CLAMPS ROTATION (4/8 RPM)
- 6 CLAMPS OPEN/CLOSE

SPECIAL VERSIONS

- VARGNAVBTB → G10356.15, G9256.15
- VARGNAVDBTH → G10356.15 + VARGNAV6315D
→ G9256.15 + VARGNAV4315D

Consolle di comando senza cavi
Wireless controle unit
Kabellose Steuersäule
Console de contrôle sans câbles
Consola de comando sin cables



HIGH BEAD BREAKING FORCE

Considerabile forza stallonatore per smontare e montare le gomme anche nei casi in cui rimangono montate al cerchio per lunghi periodi in miniere o cantieri.

Thanks to its considerable bead breaking force mounting and demounting are effortless, even when working with tyres which have been left on the rim for a long period of time in construction sites or mines.

Die bemerkenswerte Abdückerkraft erlaubt die Montage und Demontage von sehr schwierigen Reifen, die lange im Einsatz waren wie auf Baustellen, Hafen, und Zechen

La force de détalonnage est considérable permet le montage et le démontage de pneumatiques restés sur la jante longtemps comme des chantiers, des ports ou des mines.

La considerable fuerza de destalonamiento facilita el montaje y desmontaje de neumáticos que se han quedado pegados a la imanta durante mucho tiempo como zonas de obras, puertos o minas.

ELECTRO-BRAKE

STANDARD → G10360.15
G9256.15

OPTION → G9256.15SL
G9256.11SL

L'elettro-freno consente l'arresto immediato della rotazione per evitare danni al pneumatico.

The electro-brake allows immediate stopping of the rotation to avoid any damage to the tyre.

Eine elektrische Bremse arretiert sofort die Drehung, um Reifenbeschädigungen zu vermeiden.

Le moteur est équipé d'un électrofrein qui permet l'arrêt immédiat de la rotation de la roue en évitant le risque d'endommagements du pneus.

El electro-freno permite el bloqueo inmediato de la rotación para no dañar el neumático.

MINIMUM HEIGHT

330 mm (13")



Ideale anche per ruote autocarro da 19" e 22,5".

Ideal also for many 19" and 22,5" truck wheels.

Idéal auch für 19" und 22,5" Räder.

Idéal même pour roues PL de 19" et 22,5".

También para ruedas de camión de 19" y 22,5".

MINIMUM CLAMPING

Ø90 mm (3,5")



Bloccaggio interno a partire da 90 mm.

90 mm min internal clamping diameter.

Aufspannen ab 90 mm.

Blocage interne à partir de 90 mm.

Bloqueo interno a partir de 90 mm.



STANDARD MODELS

4-8 RPM ROTATION



G10360.15

G9256.15

G9256.15SL

G9256.11SL

VARIABLE SPEED

1-5-10 RPM ROTATION



G10360.15 + VARGNAV6315D

G9256.15 + VARGNAV4315D

1-5-10 RPM ROTATION

Velocità di rotazione mandrino regolabile con inverter a 10/5/1 rpm adatta anche per la scolpitura dei pneumatici.

Rotation speed adjustable with inverter at 10/5/1 rpm, also suitable for tyre treading.

Invertergesteuerte Drehgeschwindigkeit 10/5/1 rpm der Spannvorrichtung, geeignet auch zur Nacharbeitung der Reifenprofile.

Vitesse de rotation mandrin réglable avec inverter à 10/5/1 tour par minute, apte aussi pour le relief de la bande de roulement.

Velocidad de rotación del plato registrable con inverter a 10/5/1 rpm, apta para esculpir neumáticos también.

SPECIAL LEVERLESS VERSIONS

VARGNAVSL65 → G10360.15

VARGNAVSL60 → G9256.15
G9652.15SL
G9256.11SL

LEVERLESS





SPECIAL VERSION

VAR GNAV63A.15 (→ G10360.15)
 VAR GNAV43A (→ G9256.15)
 VAR GNAV43ASL (→ G9256.11SL)

Comandi su braccio mobile.
 Version with controls off the ground.
 Steuerungen auf mobilem Arm.
 Version avec commandes sur bras mobile.
 Mandos en brazo móvil.

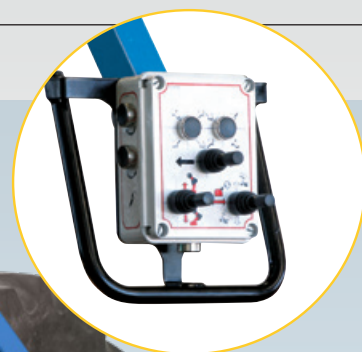

STANDARD



- 1 leva alza talloni
- 1 morsetto per cerchi
- 1 bead lifting lever
- 1 rim clamp
- 1 Montiereisen
- 1 Klemme
- 1 levier de soulèvement
- 1 étai pour jante
- 1 leva para talón
- 1 morzada para llanta

OPTIONS

Protezioni - Protections - Alufelgenschutz Protections - Protecciones

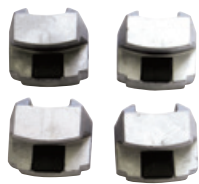

G108A1
 Kit protezioni per cerchi in lega (n°4 pezzi).
 4 clamp protections for alloy rims.
 Satz Alufelgenschutz (4 Stk).
 Kit de protection (n°4) pour jantes en alliage.
 Protección garras (n°4) para llantas de aleación.

Adattatori - Claws adapter - Adapter Adaptateurs - Adaptadores



G108A12
 Serie prolunghe presa mandrino.
 Set of extensions to increase clamping capacity.
 Verlängerungen.
 Kit rallonges prise mandrin.
 Juego extensiones agarre plato.



G108A5
 Adattatori ad aderenza maggiorata.
 Adapters with increased adherence.
 Adapter.
 Adaptateurs adhérence majeure.
 Adaptadores con adherencia suplementar.

Dispositivi vari - Various - Verschiedenes - Divers- Varios



G90A6
 Morsetto bloccatallone per cerchi in lega.
 Bead-locking clamp for alloy rims.
 Wulstklammer für Leichtmetallfelgen.
 Mors bloque-talón pour jantes en alliage.
 Mordaza de bloqueo talón para llantas de aleación.



G108A3
 Leva con testina.
 Lever with tool.
 Montiereisen.
 Levier.
 Palanca

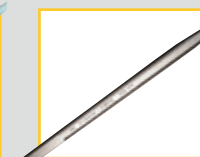

G108A13
 Leva per cerchietti.
 Rings lever.
 Montierhebel.
 Levier pour bagues.
 Palanca para anillos.

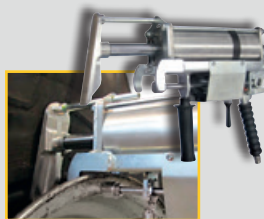

G108A34
 Premi tallone pneumatico
 Pneumatic bead pushing device
 Pneumatischer Wulstrücker
 Pousse-talón pneumatique
 Prensa talón neumático



G108A16
 Pennello.
 Brush.
 Montagepinsel.
 Pinceau.
 Brocha profesional.



G800A37 (3,5 kg / 8 lb)
 Pasta di montaggio.
 Mounting grease.
 Montagepaste.
 Pâte de montage.
 Jabón profesional

NOTE:
 8 x carton
 160 x pallet



G 9256.15 SL



11" - 43"
11" - 56"
(+G108A12)



2360 mm (93")



1500 mm (59")

G 9256.11 SL



11" - 43"
11" - 56"
(+G108A12)



2360 mm (93")



1100 mm (43")



AUTOMATIC LIFTING



AUTOMATIC MOVEMENT



QUICK MANUAL ROTATION



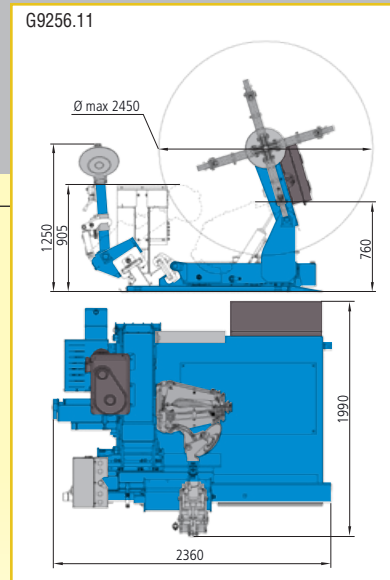
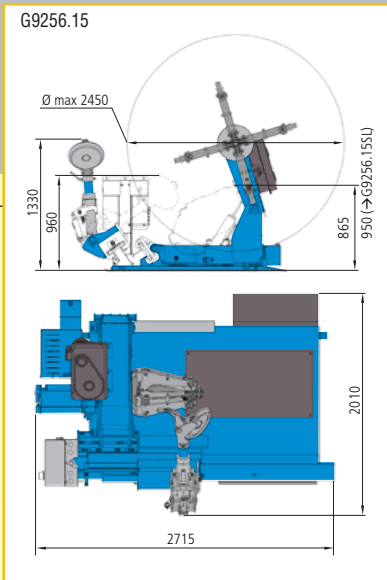
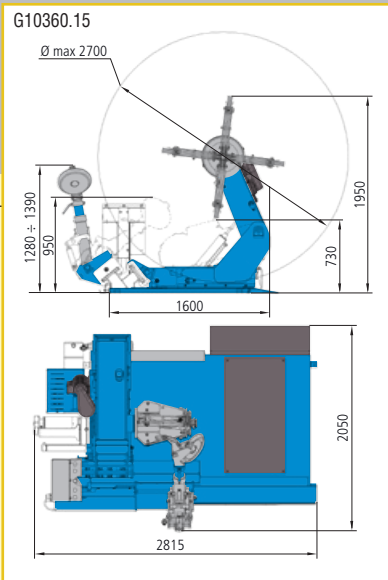

DATI TECNICI	TECHNICAL DATA	TECHNISCHE DATEN	DONNEES TECHNIQUES	DATOS TÉCNICOS	G10360.15 + VARGNAV6315D	G10360D.15
Motore rotazione mandrino	Chucking unit rotation motor	Motor für Drehung der Spannvorrichtung	Moteur rotation mandrin	Motor rotación plato	1,5 - 2,2 kW	2,2 kW
Motore centralina	Hydraulic drive unit motor	Hydraulikmotor	Moteur de la pompe	Motor unidad hidráulica	1,85 - 2,5 kW	
Ø cerchi	Rim Ø	Felgen-Ø	Ø de la jante	Ø de llantas	11" - 43"	
Ø cerchi con G108A12	Rim Ø with G108A12	Felgen mit G108A12	Ø de la jante avec G108A12	Ø de llantas con G108A12	11" - 60"	
Ø est. ruota ammesso	Max. wheel Ø	Raddurchmesser	Ø de la roue	Ø maximo ext. rueda	2700 mm (106")	
Larghezza max. ruota	Max. allowed wheel width	Max. Radbreite	Largeur maxi de la roue	Ancho max. rueda	1500 mm (59")	
Peso	Weight	Gewicht	Poids	Peso	1400 kg (3686 lbs)	
Potenza stallonatore	Bead breaker power	Abdrückerkraft	Force du détalonneur	Force du détalonneur	37000N	
Peso max ruota	Max wheel weight	Maximales Radgewicht	Poids maxi de la roue	Poids maxi de la roue	2600 kg (5732 lbs)	
Velocità di rotazione mandrino (giri/min)	Chuck rotation speed (rev/min)	Spervorrichtungs-Drehgeschwindigkeit (U./min.)	Vitesse de rotation du mandrin (tours/min.)	Velocidad de rotación mandril (rev./min.)	4-8	1-5-10 rpm
Coppia max al mandrino	Max. torque to chuck	Max. Spervorrichtungs-Drehmoment	Couple max. au mandrin	Par máx al mandril	5800 Nm (4275 FtLbs)	

DATI TECNICI	TECHNICAL DATA	TECHNISCHE DATEN	DONNEES TECHNIQUES	DATOS TÉCNICOS	G9256.15	G9256.15 + VARGNAV4315D	G9256.15SL
Motore rotazione mandrino	Chucking unit rotation motor	Motor für Drehung der Spannvorrichtung	Moteur rotation mandrin	Motor rotación plato	1,3 - 1,85 kW	2,2 kW	1,3 - 1,85 kW
Motore centralina	Hydraulic drive unit motor	Hydraulikmotor	Moteur de la pompe	Motor unidad hidráulica	1,85 - 2,5 kW		
Ø cerchi	Rim Ø	Felgen-Ø	Ø de la jante	Ø de llantas	11" - 43"		
Ø cerchi con G108A12	Rim Ø with G108A12	Felgen mit G108A12	Ø de la jante avec G108A12	Ø de llantas con G108A12	11" - 56"		
Ø est. ruota ammesso	Max. wheel Ø	Raddurchmesser	Ø de la roue	Ø maximo ext. rueda	2360 mm (93")		
Larghezza max. ruota	Max. allowed wheel width	Max. Radbreite	Largeur maxi de la roue	Ancho max. rueda	1500 mm (59")		
Peso	Weight	Gewicht	Poids	Peso	1150 kg	1120 kg	
Potenza stallonatore	Bead breaker power	Abdrückerkraft	Force du détalonneur	Force du détalonneur	32000N		
Peso max ruota	Max wheel weight	Maximales Radgewicht	Poids maxi de la roue	Poids maxi de la roue	2300 kg (5070 lbs)		
Velocità di rotazione mandrino (giri/min)	Chuck rotation speed (rev/min)	Spervorrichtungs-Drehgeschwindigkeit (U./min.)	Vitesse de rotation du mandrin (tours/min.)	Velocidad de rotación mandril (rev./min.)	4-8 rpm	1-5-10 rpm	4-8 rpm
Coppia max al mandrino	Max. torque to chuck	Max. Spervorrichtungs-Drehmoment	Couple max. au mandrin	Par máx al mandril	5300 Nm (3906 FtLbs)		

DATI TECNICI	TECHNICAL DATA	TECHNISCHE DATEN	DONNEES TECHNIQUES	DATOS TÉCNICOS	G9256.11SL		
Motore rotazione mandrino	Chucking unit rotation motor	Motor für Drehung der Spannvorrichtung	Moteur rotation mandrin	Motor rotación plato	1,3 - 1,85 kW		
Motore centralina	Hydraulic drive unit motor	Hydraulikmotor	Moteur de la pompe	Motor unidad hidráulica	1,85 - 2,5 kW		
Ø cerchi	Rim Ø	Felgen-Ø	Ø de la jante	Ø de llantas	11" - 43"		
Ø cerchi con G108A12	Rim Ø with G108A12	Felgen mit G108A12	Ø de la jante avec G108A12	Ø de llantas con G108A12	11" - 56"		
Ø est. ruota ammesso	Max. wheel Ø	Raddurchmesser	Ø de la roue	Ø maximo ext. rueda	2360 mm (93")		
Larghezza max. ruota	Max. allowed wheel width	Max. Radbreite	Largeur maxi de la roue	Ancho max. rueda	1100 mm (43")		
Peso	Weight	Gewicht	Poids	Peso	1020 kg (2250 lbs)		
Potenza stallonatore	Bead breaker power	Abdrückerkraft	Force du détalonneur	Force du détalonneur	32000N		
Peso max ruota	Max wheel weight	Maximales Radgewicht	Poids maxi de la roue	Poids maxi de la roue	2000 kg (4400 lbs)		
Velocità di rotazione mandrino (giri/min)	Chuck rotation speed (rev/min)	Spervorrichtungs-Drehgeschwindigkeit (U./min.)	Vitesse de rotation du mandrin (tours/min.)	Velocidad de rotación mandril (rev./min.)	4-8		
Coppia max al mandrino	Max. torque to chuck	Max. Spervorrichtungs-Drehmoment	Couple max. au mandrin	Par máx al mandril	5300 Nm (3690 FtLbs)		



Ravaglioli S.p.A.
 via 1° maggio 3
 Fraz. Pontecchio M.
 40037 Sasso Marconi (Bo) - Italia
 Tel. +39 - 051 - 6781511
 Fax +39 - 051 - 846349
 rav@ravaglioli.com
 www.ravaglioli.com

RAV France
 4, Rue Longue Raie
 ZAC de la Tremblaie
 91220 Le Plessis Pâté
 Tel. 01.60.86.88.16
 Fax 01.60.86.82.04
 rav@ravfrance.fr

Ravaglioli Deutschland
 Hüfinger Strasse 55
 78199 Bräunlingen
 Tel. 08165-646956
 Fax 08165-646958
 ravd@ravaglioli.com

RAV Equipment UK LTD
 Prince Albert House
 20 King Street
 Maidenhead, SL6 1DT
 Tel. +39 - 0516781522
 rav@ravaglioli.com

RAV en Belgique
 Nederlandstalig
 Tel. 0498-162016
 Fax 016-781025
 Zone Francophone
 Tel. 0498-163016
 Fax +32 78 055 030

RAV Equipos España S.L.U.
 Avenida Europa 17
 Pol. Ind. de Constanti
 Tarragona 43120
 Tel. 977 524525
 Fax 977 524532
 ravequipos@ravaglioli.e.telefonica.net

a DOWER company

DRN24U (09)

Le caratteristiche tecniche e gli allestimenti presentati in questo prospetto possono subire variazioni. Le immagini riprodotte non sono vincolanti.
 Technical data and composition presented in this catalogue may vary. Pictures reproduced are only indicative.
 Die techn. Daten und die Ausrüstungen, die in diesem Prospekt enthalten sind, können Änderungen erfahren. Deshalb sind die Abbildungen unverbindlich.
 Les caractéristiques techniques et les compositions présentées dans ce prospectus peuvent subir des variations. Les images reproduites n'ont qu'une valeur indicative.
 Las características técnicas y las composiciones ilustradas en este folleto pueden sufrir variaciones. Las imágenes propuestas son solamente indicativas.

