

COMPACT tyre changer for INTENSIVE USE.

S557



i For truck and bus fleets, professional truck tyre service and high volume shops. Suitable for both tube and tubeless tyres.



S557

www.giuliano-automotive.com

TRUCK TYRE CHANGER 13" - 27" FOR TRUCK AND BUS WHEELS



💡 Suitable for control console installation on pivoting arm (optional).

✔ Clamping chuck is powered by **two speed electric motor**.

✔ Hydraulic movement of clamping chuck holding arm (up-down).

✔ Hydraulic travel movement of operating arm carriage (left-right).

✔ Operating arm and clamping chuck arm facing each other.

✔ Wheel clamping by fully hydraulic operated jaws.

✔ Rim center hole clamping range \varnothing 80 - 700 mm.

✔ Low profiled platform eases the loading of heavy wheels.

✔ Clamping chuck **minimum height** from ground **330 mm** (center).



YouTube

Watch the video

✔ Double tool (disk + finger) **manual rotation**.



✔ Operating arm **manual tilting** and **travelling** on carriage.



✔ All motions controlled by **console and pedal box**.

✔ **Emergency safety button** on control console, for stopping all functions.

✔ Designed, built and engineered in Italy.



Available in:

- Blue Trim
- Black Trim
- Red Trim



Multistage clamping jaws

STANDARD FEATURES

Rim clamping range	13" - 27"
Max. tyre diameter	1600 mm (63")
Max. tyre width	780 mm (30")
Bead breaker force	18300 N
Operating pressure	130 bar (1885 Psi)
Power supply	400V - 3ph / 2 speed *
Hydraulic pump motor power	1,1 kW
Clamping chuck motor power	1,3 / 1,8 kW
Net weight	560 kg
Max. tyre assembly weight	1500 kg
Max. overall dimensions	1430x1750x1550+1740x1270 mm

* Other voltages and frequencies available upon request

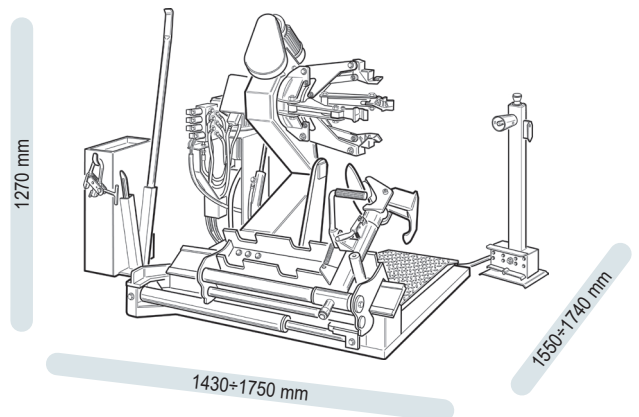

STANDARD ACCESSORIES



- Short bead lifting lever
- Long bead lifting lever, for agriculture tyres
- Mounting clamp for steel rims