

- **Gru idrauliche** • Grúas hidráulicas
- Hydraulic cranes • Hydraulische Kräne



Code T1580: 500 Kg
Code T1581: 1000 Kg

Code T1582: 1500 Kg
Code T1583: 2000 Kg

Code **T1580-T1581**
Code **T1582-T1583**

Pompa doppio effetto, serie pesante.

Caratteristiche Tecniche:

valvola limitatrice di carico. Comando uomo presente.

Bomba efecto doble - versión pesada.

Características técnicas:

válvula de seguridad para sobrecarga. Controles a bordo.

Double action pump, heavy duty series.

Technical features:

overload safety-valve. "Dead man" controls.

Doppeltwirkende Pumpe, schwere Serie.

Technische Eigenschaften:

UL-Sicherheitsventil. Einmann-Knopf-Betätigung.

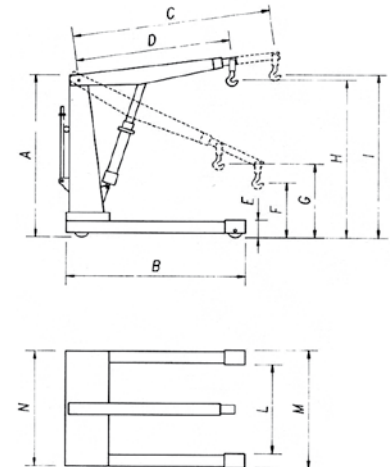

	T1580	T1581	T1582	T1583
A	1610	1740	1850	2000
B	1280	1500	1790	1970
C	1300	1550	1840	1950
D	1000	1250	1390	1500
E	150	165	195	220
F	460	525	470	530
G	680	720	750	810
H	2180	2440	2860	2930
I	2380	2650	3280	3280
L	775	900	1000	1150
M	885	1010	1150	1350
N	600	700	1040	1340
kg	80	130	220	300

- **Tabella peso braccio**
- Capacidad de elevación según agujeros
- Arm load capacity
- Einzelarmlast Kapazität

	T1580	T1581	T1582	T1583
1 kg	500	1000	1500	2000
2 kg	400	800	1200	1500
3 kg	250	500	800	1000
4 kg	150	300	500	600

