

- **Gru idrauliche** • Grúas hidráulicas
- Hydraulic cranes • Hydraulische Kräne

Code T1586: 500 Kg  
Code T1587: 1000 Kg



## Code T1586-T1587

Pompa semplice effetto, versione pieghevole.

**Caratteristiche Tecniche:**  
valvola limitatrice di carico. Comando uomo presente.

Bomba efecto simple, versión flexible.

**Características técnicas:**  
válvula de seguridad para sobrecarga. Controles a bordo.

Single action pump, folding version.

**Technical features:**  
overload safety-valve. "Dead man" controls.

Einfachwirkende Pumpe, klappbare Ausführung.

**Technische Eigenschaften:**  
UL-Sicherheitsventil. Einmann-Knopf-Betätigung.

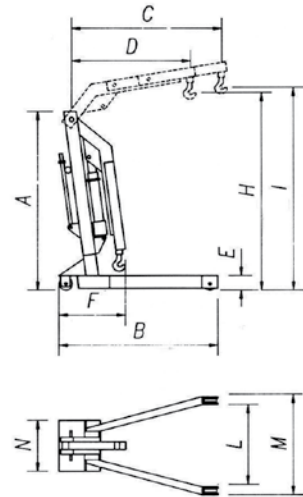

	T1586	T1587
<b>A</b>	1600	1650
<b>B</b>	1540	1560
<b>C</b>	1200	1380
<b>D</b>	900	1080
<b>E</b>	140	165
<b>F</b>	330	470
<b>G</b>	1940	2200
<b>H</b>	2070	2400
<b>I</b>	2400	2750
<b>L</b>	720	835
<b>M</b>	885	1000
<b>N</b>	440	550
<b>kg</b>	80	110

	T1586	T1587
<b>1 kg</b>	500	1000
<b>2 kg</b>	400	800
<b>3 kg</b>	350	650
<b>4 kg</b>	250	450

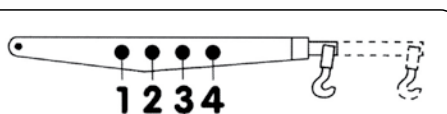

- **Tabella peso braccio**
- **Capacidad de elevación según agujeros**
- **Arm load capacity**
- **Einzelarmlast Kapazität**