



- **Gru idrauliche** • Grúas hidráulicas
- Hydraulic cranes • Hydraulische Kräne

Code T1589: 500 Kg
Code T1590: 1000 Kg



Code T1589-T1590

Pompa doppio effetto, versione pieghevole.

Caratteristiche Tecniche:

valvola limitatrice di carico. Comando uomo presente.

Bomba efecto doble, versión flexible.

Características técnicas:

válvula de seguridad para sobrecarga. Controles a bordo.

Double action pump, folding version.

Technical features:

overload safety-valve. "Dead man" controls.

Doppeltwirkende Pumpe, klappbare Ausführung.

Technische Eigenschaften:

UL-Sicherheitsventil. Einmann-Knopf-Betätigung.

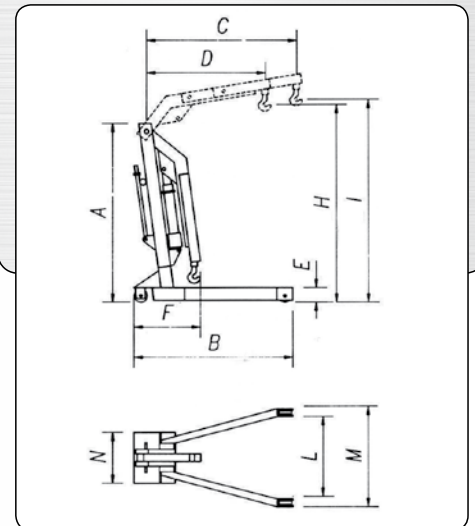

	T1589	T1590
A	1600	1650
B	1540	1560
C	1200	1380
D	900	1080
E	140	165
F	330	470
G	1940	2200
H	2070	2400
I	2400	2750
L	720	835
M	885	1000
N	440	550
kg	80	110

	T1589	T1590
1 kg	500	1000
2 kg	400	800
3 kg	350	650
4 kg	250	450

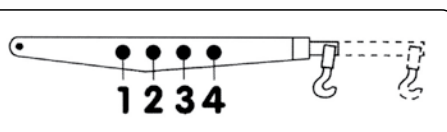

- **Tabella peso braccio**
- *Capacidad de elevación según agujeros*
- *Arm load capacity*
- *Einzelarmlast Kapazität*

